

# RCB001

## Voltage Regulator Module (VRM) for Pentium® Pro Processors

### Features

- Programmable 2.0V to 3.5V output from 5V supply
- Maximum output current 12.4A
- Typical Efficiency > 84%
- Total output accuracy typically  $\pm 3\%$
- Short circuit protection
- Power Good output
- Output Enable function
- Excellent transient response
- Meets Intel Pentium Pro VRM specifications

### Applications

- Pentium Pro motherboard VRM module
- Programmable power supply module
- Template for motherboard implementation

### Description

The RCB001 VRM module is a programmable DC-DC voltage regulator module designed to deliver the selectable processor core voltage required by the Pentium Pro micro-processor family. This VRM module provides the flexibility to board designers to support the entire Pentium Pro processor family with a single motherboard design. The RCB001 design takes full advantage of a proprietary Fairchild programmable DC-DC voltage controller IC which integrates the DAC function as well as the Power Good and Output Enable features. The result is a voltage regulator module that uses a minimum number of external components to achieve high reliability at a competitive cost. The RCB001 provides an extremely well regulated voltage selectable from 2.0V to 3.5V. Voltage selection is accomplished through a 4 bit digital input (VID0 - VID3) and can be incremented in 100mV steps. The Power Good open collector output provides a logic LOW state when an out-of-tolerance voltage is detected at the VRM output. Other features include high efficiency, short circuit protection, output enable and low package weight. The RCB001 VRM module is designed as a point-of-load converter for the Pentium Pro processor, thus minimizing the distribution losses normally occurring when drawing high currents from a centralized power supply.

### Block Diagram

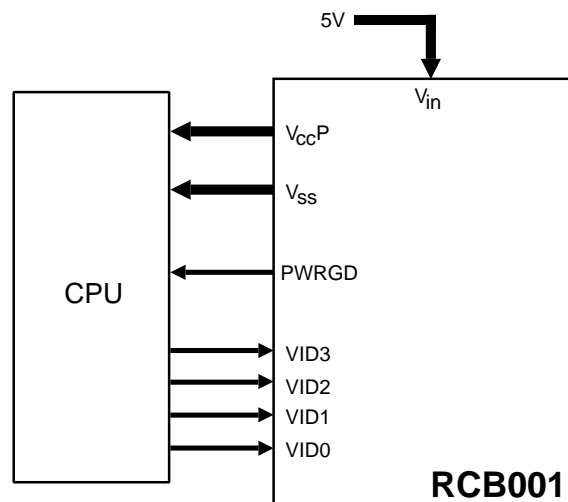

**Mechanical Dimensions (mm):**

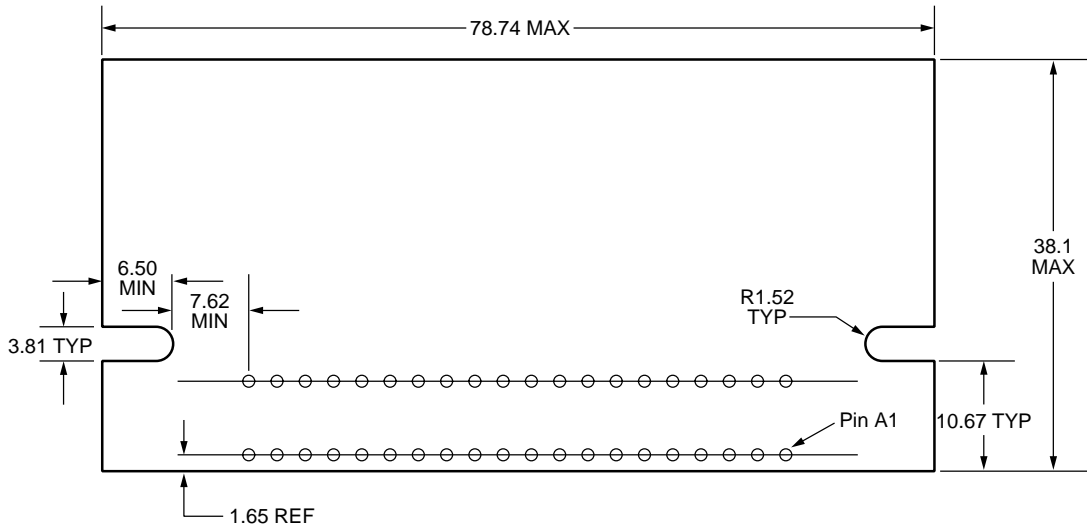

**Pin Orientation  
(Top View)**

(socket: AMPMOD2 532956-7 or equivalent)

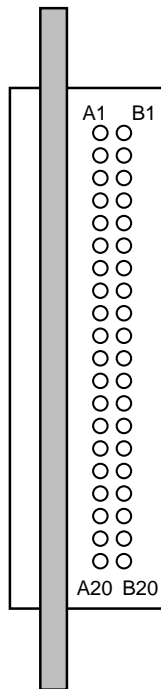

**Table 1. VRM Pin Definitions**

Pin#	Row A	Row B
1	5VIN	5VIN
2	5VIN	5VIN
3	5VIN	5VIN
4	NC <sup>1</sup>	NC <sup>1</sup>
5	NC <sup>1</sup>	NC <sup>1</sup>
6	NC <sup>1</sup>	OUTEN <sup>2</sup>
7	VID0	VID1
8	VID2	VID3
9	NC <sup>1</sup>	PWRGD
10	VCCP	VSS
11	VSS	VCCP
12	VCCP	VSS
13	VSS	VCCP
14	VCCP	VSS
15	VSS	VCCP
16	VCCP	VSS
17	VSS	VCCP
18	VCCP	VSS
19	VSS	VCCP
20	VCCP	VSS

**Notes:**

- 1. Not used on module; no current is drawn.
- 2. This pin is not used on the RCB001-12A.

### VRM Connector Pin Reference

Pin Name	Input/Output	Function
Power-Good (PWRGD) (Open collector TTL output)	O	PWRGD = High, output voltage within specifications PWRGD = Low, output voltage not within specifications (nominal or selected voltage $\pm 10\%$ ) The PWRGD signal will change to the proper state within 5ms of the output coming into or going out of its specified range.
Output Enable (OUTEN) <sup>1</sup> (Open collector TTL input)	I	OUTEN = Floating or high, output enabled OUTEN = Low, output disabled and PWRGD = Low
Voltage Identification (VID0 to VID3) (Open collector TTL input)	I	These four signals are used to indicate the voltage required by the processor. See Table 2.
5 VIN	I	Module supply voltage.
VCCP	O	Processor core VCC
VSS	I, O	Ground reference voltage.

**Note:**

1. This pin is not used on the RCB001-12A.

### Electrical Specifications

(VIN = +5V, TA = 0 to 70°C unless otherwise specified)

Parameter	Test Conditions	Min.	Typ.	Max.	Units
<b>Input Specifications</b>					
Input Voltage, VIN		4.75	5	5.25	V
<b>Output Specifications</b>					
Output Voltage (VCCP) Range	Intel VID code, Table 2	2.0		3.5	V
DC Output Current, IOUT	RCB001-12 and RCB001-12A	0.5		12.4	A
Set Point Accuracy <sup>1</sup>	ILOAD = 5.25A, TA = 25°C		$\pm 0.8$	$\pm 1.5$	%
DC Load Regulation	ILOAD = 0.5A to 12.4A		0.8	$\pm 1.5$	%
Line Regulation	$4.75 \leq V_{IN} \leq 5.25$		0.1	$\pm 0.2$	%
Output Ripple and Noise	ILOAD = 10A, BW = 20MHz		30		mVpp
Output Temperature Drift			+20		ppm/°C
Load Transient	ILOAD = 0.5A to 10A, 30A/ $\mu$ Sec VID code 0010 (VCCP = 3.3V)		100	120	mV
Cumulative Accuracy	All Conditions, see Note 2		$\pm 3$	$\pm 5$	%
Efficiency	ILOAD = 0.5A	40	67		%
	ILOAD = 10A	80	84		%
<b>General Specifications</b>					
Switching Frequency			650		kHz
Short Circuit Protection			16		A

**Notes:**

1. Set Point Accuracy is defined as the static accuracy of the output voltage at 5.25A @ TA = 25°C.
2. Cumulative Accuracy includes Setpoint Accuracy, Output Temperature Drift, Line and Load Regulation, Output Ripple/Noise and Load Transient Response.

**Table 2. Voltage Identification (VID) and Overall Regulation<sup>1</sup>**

Pentium Pro Processor Pins				Output ( $V_{CCP}$ )		
VID3	VID2	VID1	VID0	Min.	Nominal	Max.
1	1	1	1	1.900 V	2.0V	2.100V
1	1	1	0	1.995V	2.1V	2.205V
1	1	0	1	2.090V	2.2V	2.310V
1	1	0	0	2.185V	2.3V	2.415V
1	0	1	1	2.280V	2.4V	2.520V
1	0	1	0	2.375V	2.5V	2.625V
1	0	0	1	2.470V	2.6V	2.730V
1	0	0	0	2.565V	2.7V	2.835V
0	1	1	1	2.660V	2.8V	2.940V
0	1	1	0	2.755V	2.9V	3.045V
0	1	0	1	2.850V	3.0V	3.150V
0	1	0	0	2.945V	3.1V	3.255V
0	0	1	1	3.040V	3.2V	3.360V
0	0	1	0	3.135V	3.3V	3.465V
0	0	0	1	3.230V	3.4V	3.570V
0	0	0	0	3.325V	3.5V	3.675V

0 = Processor pin connected to VSS

1 = Processor pin open

**Note:**

- Includes set point accuracy, load transient, ripple and noise, thermal drift, load regulation and line regulation.

**Ordering Information**

Part Number <sup>1</sup>	Input	Maximum DC Output Current	Comments
RCB001-12	5V	12.4A	
RCB001-12A	5V	12.4A	No Output Enable

**Note:**

- Please refer to our Application Note 42 (AP-42) for more information on the board level voltage regulator design using Fairchild's DC-DC voltage controllers (RC5040 and RC5042).

**LIFE SUPPORT POLICY**

FAIRCHILD'S PRODUCTS ARE NOT AUTHORIZED FOR USE AS CRITICAL COMPONENTS IN LIFE SUPPORT DEVICES OR SYSTEMS WITHOUT THE EXPRESS WRITTEN APPROVAL OF THE PRESIDENT OF FAIRCHILD SEMICONDUCTOR CORPORATION. As used herein:

- Life support devices or systems are devices or systems which, (a) are intended for surgical implant into the body, or (b) support or sustain life, and (c) whose failure to perform when properly used in accordance with instructions for use provided in the labeling, can be reasonably expected to result in a significant injury of the user.
- A critical component in any component of a life support device or system whose failure to perform can be reasonably expected to cause the failure of the life support device or system, or to affect its safety or effectiveness.